

DIMENSIONS FOR LARGE POLARIZATION RIB TERMINAL ONLY

NOTES: (UNLESS OTHERWISE SPECIFIED)

- MATING TERMINAL SHOWN ON SD-33000-001
- MATERIAL: ASTM B422, UNS C19025, HR04
THICKNESS: 0.30 mm ±0.01
TEMPER: FULL HARD (REF)
TENSILE: 496 MIN MPA
- TIN PLATED TERMINAL FINISH:
OVERALL UNDERPLATE ELECTRODEPOSITED NICKEL
OVERALL ELECTRODEPOSITED REFLOW TIN
- GOLD PLATED TERMINAL FINISH
OVERALL UNDERPLATE ELECTRODEPOSITED DUCTILE SULFAMATE NICKEL
CONTACT AREA - ELECTRODEPOSITED GOLD
GRIP AREA - ELECTRODEPOSITED 100% TIN MATTE FINISH
- SILVER PLATED TERMINAL FINISH
OVERALL UNDERPLATE ELECTRODEPOSITED DUCTILE SULFAMATE NICKEL
CONTACT AREA - ELECTRODEPOSITED PURE SILVER (0.5% MAX
IMPURITIES) SEMI-BRIGHT FINISH
- SILVER ANTI-TARNISH : EVABRITE
GRIP AREA - ELECTRODEPOSITED 100% TIN MATTE FINISH
- MEETS PERFORMANCE SPECIFICATION FOR CABLE TO TERMINAL
ELECTRICAL CRIMPS PER SAE/USCAR-21 (8/2001)
- MEETS PERFORMANCE STANDARD FOR AUTOMOTIVE ELECTRICAL
CONNECTOR SYSTEMS FOR SAE/USCAR-2, REV. 4 (TEMP CLASS 3)
(5/2004)
- MEETS ELECTRICAL CONNECTION SYSTEM DESIGN SPECIFICATION
(SDS) REV.11 (5/2002)
- MEETS FIELD CORRELATED LIFE TEST (FCLT) PER
SAE/USCAR-20 (6/2004)
- MEETS WIRING COMPONENT DESIGN GUIDELINES SAE/USCAR-12
REV 2 (12/2001)
- TSC ON A DIMENSION TO BE INTERPRETED AS DISTANCE TO
A THEORETICAL SHARP CORNER AS IF THE RADIUS WERE NOT
PRESENT
- REFERENCE 97BG-14474-AAB FOR LARGE POLARIZATION RIB
CAVITY SPECIFICATION
- INSERTION FORCE (TIN) AVG. FROM PV TESTING =
3.8N LARGE POLARIZATION RIB
3.5N SMALL POLARIZATION RIB
(REFERENCE)
- ALL DIMENSIONS EXCEPT (33), (34), (41) & (42) ARE COMMON TO
BOTH SMALL AND LARGE POLARIZATION RIB TERMINALS
- REFERENCE PK-31300-516 FOR REEL DIRECTION
- REFERENCE AS-33012-002 FOR CRIMP INFORMATION

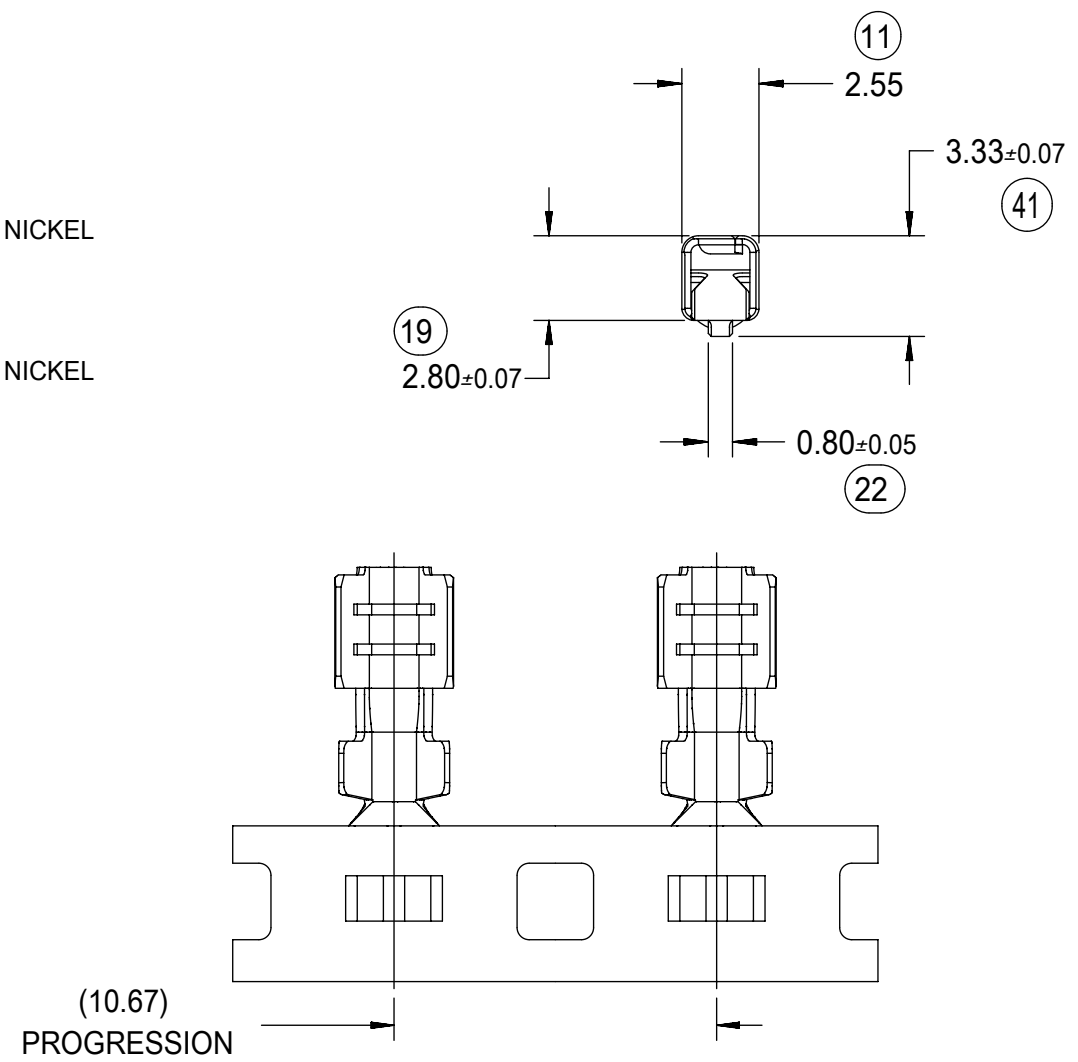

STAMP PLATING TYPE
Sn-TIN, Au-GOLD OR
Ag-SILVER IN THIS
AREA

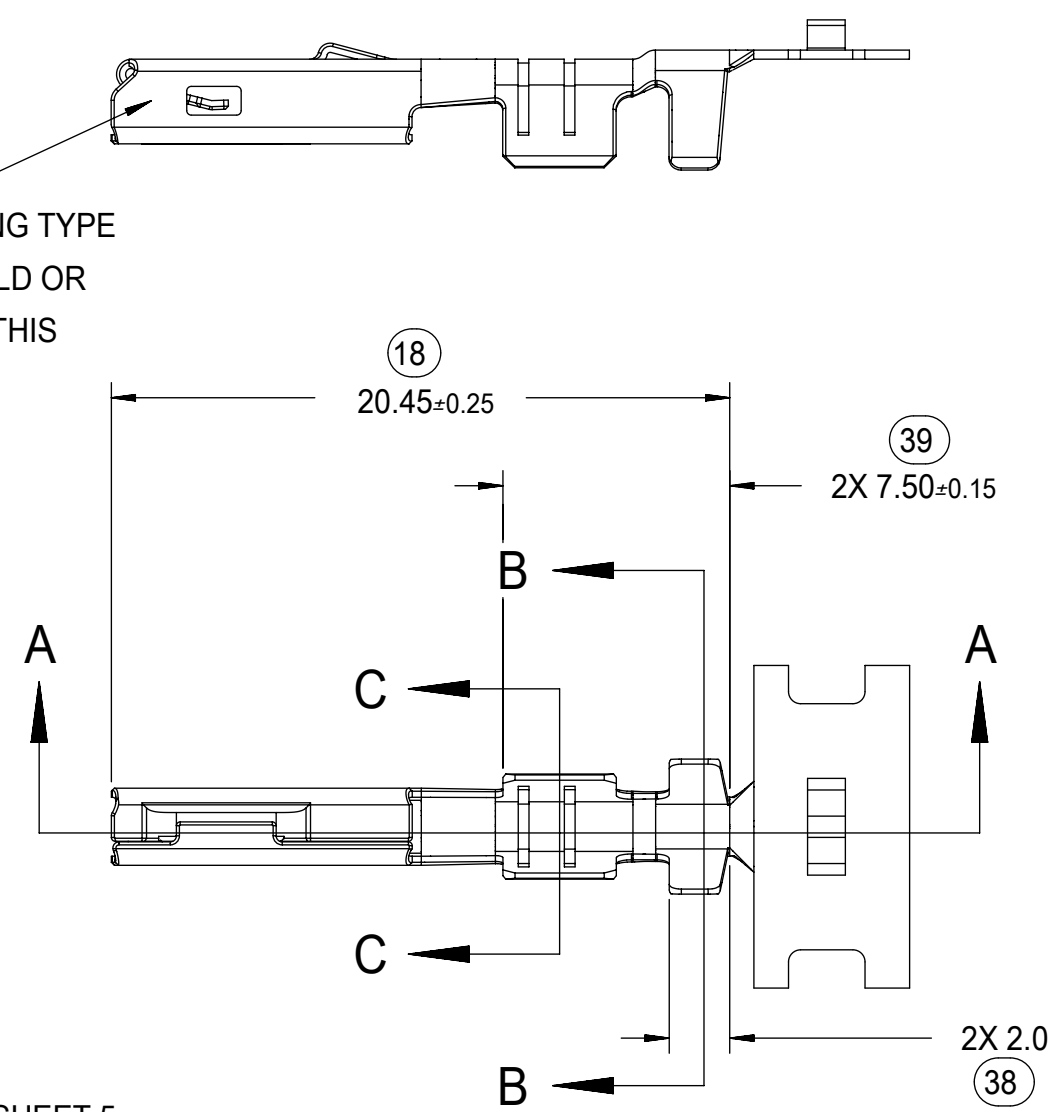

SEE SHEET 5
FOR M3 GRIP CODE
TERMINAL

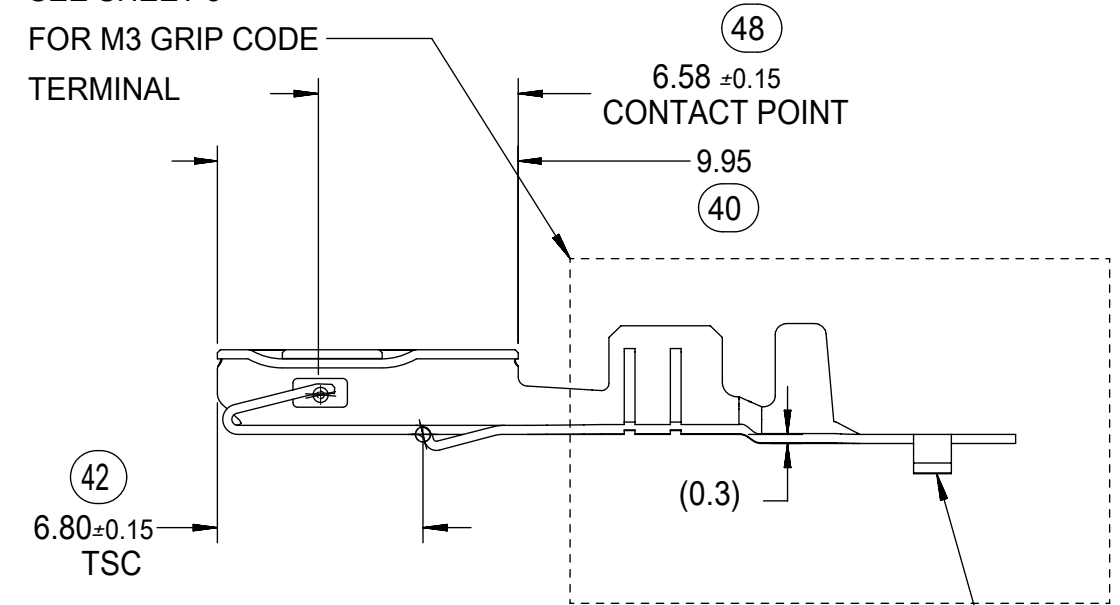

SECTION A-A

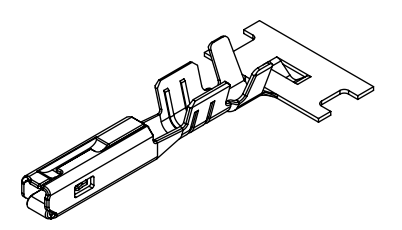

SCALE 2:1

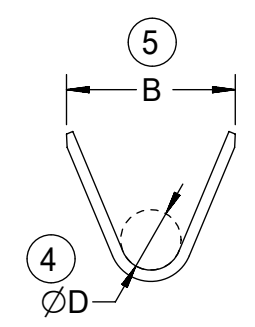

SECTION B-B
SCALE 5:1

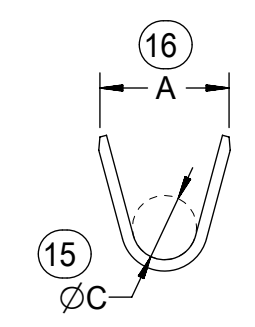

SECTION C-C
SCALE 5:1

CARRIER BUMP DIRECTION
POINTS DOWN FOR TIN PLATED TERMINALS
POINTS UP FOR PRECIOUS PLATED TERMINALS

SYMBOLS										THIS DRAWING CONTAINS INFORMATION THAT IS PROPRIETARY TO MOLEX ELECTRONIC TECHNOLOGIES, LLC AND SHOULD NOT BE USED WITHOUT WRITTEN PERMISSION									
DIMENSION UNITS		SCALE		CURRENT REV DESC:															
mm		4:1		EC NO: 645050															
GENERAL TOLERANCES (UNLESS SPECIFIED)		DRWN: BSKANTHARAJU 2020/09/03																	
ANGULAR TOL ± 3.0°		CHK'D: JCUATACERVAN 2020/09/18																	
4 PLACES ±		APPR: JCUATACERVAN 2020/09/18																	
3 PLACES ±		INITIAL REVISION:																	
2 PLACES ± 0.10		DRWN: LPULLIAM 2005/06/21																	
1 PLACE ± 0.3		APPR: BMOSEY 2005/06/22																	
0 PLACES ±		DRAFT WHERE APPLICABLE MUST REMAIN WITHIN DIMENSIONS		THIRD ANGLE PROJECTION		DRAWING		SERIES		DOCUMENT NUMBER		DOC TYPE		DOC PART		REVISION			
		C-SIZE		33012		SD-33012-002		PSD		001		D							
		SEE TABLE		GENERAL MARKET		1 OF 5													

FAMILY	GENDER	SEALING	PLATING	PART NUMBER	PAYOFF DIRECTION	GRIP CODE	WIRE SIZES *	A ±0.30	B ±0.30	C ±0.30	D ±0.30	SPECIAL CHARACTERISTICS
MX150	RECEPTACLE	MAT SEAL	Sn	33012-2001	RIGHT (B)	14	16/14AWG 1.25-2.00mm ²	3.9	4.4	1.7	1.6	HIGH PERFORMANCE Sn
				33012-3001	LEFT (D)							
				33012-2002	RIGHT (B)	18	20/18AWG 0.75-1.00mm ²	3.3	3.1	1.3	1.4	
				33012-3002	LEFT (D)							
				33012-2003	RIGHT (B)	22	22AWG	2.5	2.6	0.9	1.0	
				33012-3003	LEFT (D)							
			33012-2004	RIGHT (B)	M3	0.35-0.50mm ²	2.5	2.7	0.9	1.54 ±0.1		
			33012-3004	LEFT (D)								
			Au	33001-2003	RIGHT (B)	14	16/14AWG 1.25-2.00mm ²	3.9	4.4	1.7	1.6	HIGH PERFORMANCE Au
				33001-3003	LEFT (D)							
				33001-2004	RIGHT (B)	18	20/18AWG 0.75-1.00mm ²	3.3	3.1	1.3	1.4	
				33001-3004	LEFT (D)							
				33001-2005	RIGHT (B)	22	22AWG	2.5	2.6	0.9	1.0	
				33001-3005	LEFT (D)							
			33001-2006	RIGHT (B)	M3	0.35-0.50mm ²	2.5	2.7	0.9	1.54 ±0.1		
			33001-3006	LEFT (D)								
			Ag	33001-4001	RIGHT (B)	14	16/14AWG 1.25-2.00mm ²	3.9	4.4	1.7	1.6	HIGH PERFORMANCE Ag
				33001-5001	LEFT (D)							
33001-4002	RIGHT (B)	18		20/18AWG 0.75-1.00mm ²	3.3	3.1	1.3	1.4				
33001-5002	LEFT (D)											
33001-4003	RIGHT (B)	22		22AWG	2.5	2.6	0.9	1.0				
33001-5003	LEFT (D)											
33001-4005	RIGHT (B)	M3	0.35-0.50mm ²	2.5	2.7	0.9	1.54 ±0.1					
33001-5005	LEFT (D)											

LARGE POLARIZATION RIB - NOT TO BE USED IN MX150 SEALED CONNECTORS

MX150	RECEPTACLE	UNSEALED	Sn	33012-2021	RIGHT (B)	14	16/14AWG 1.25-2.00mm ²	3.9	4.4	1.7	1.6	HIGH PERFORMANCE Sn
				33012-3021	LEFT (D)							
				33012-2022	RIGHT (B)	18	20/18AWG 0.75-1.00mm ²	3.3	3.1	1.3	1.4	
				33012-3022	LEFT (D)							
				33012-2023	RIGHT (B)	22	22AWG 0.35-0.50mm ²	2.5	2.6	0.9	1.0	
				33012-3023	LEFT (D)							
			Au	33001-2021	RIGHT (B)	14	16/14AWG 1.25-2.00mm ²	3.9	4.4	1.7	1.6	HIGH PERFORMANCE Au
				33001-3021	LEFT (D)							
				33001-2022	RIGHT (B)	18	20/18AWG 0.75-1.00mm ²	3.3	3.1	1.3	1.4	
				33001-3022	LEFT (D)							
				33001-2023	RIGHT (B)	22	22AWG 0.35-0.50mm ²	2.5	2.6	0.9	1.0	
				33001-3023	LEFT (D)							
			Ag	33001-4021	RIGHT (B)	14	16/14AWG 1.25-2.00mm ²	3.9	4.4	1.7	1.6	HIGH PERFORMANCE Ag
				33001-5021	LEFT (D)							
				33001-4022	RIGHT (B)	18	20/18AWG 0.75-1.00mm ²	3.3	3.1	1.3	1.4	
				33001-5022	LEFT (D)							
				33001-4023	RIGHT (B)	22	22AWG 0.35-0.50mm ²	2.5	2.6	0.9	1.0	
				33001-5023	LEFT (D)							

* REFERENCE AS-33012-002 FOR SPECIFIC WIRE TYPES

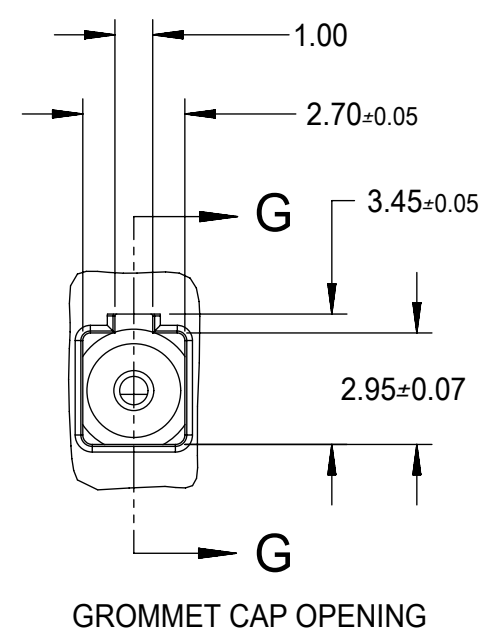
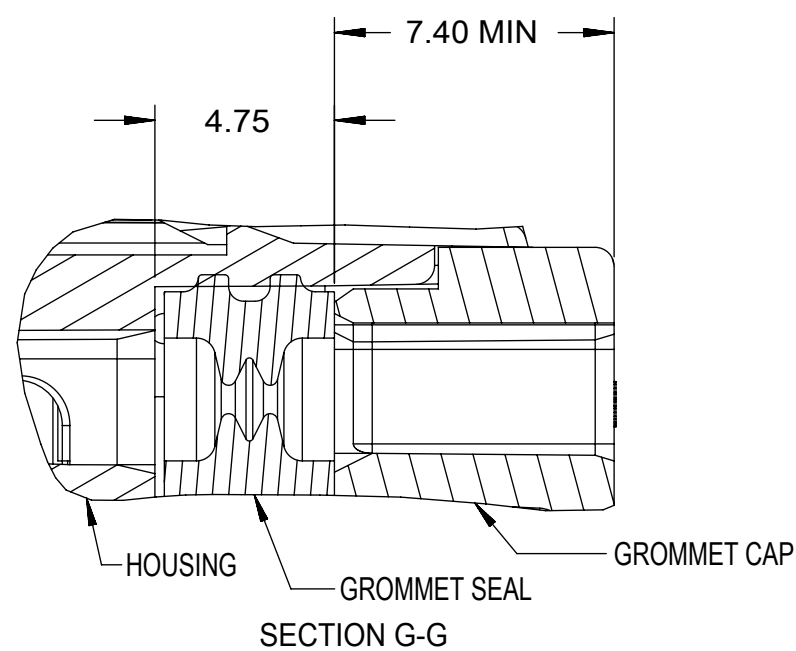

GROMMET SEAL / CAP CONFIGURATION TO MODIFY LARGE POLARIZATION RIB CAVITY TO ACCEPT SMALL POLARIZATION RIB APPLICATIONS

SYMBOLS	THIS DRAWING CONTAINS INFORMATION THAT IS PROPRIETARY TO MOLEX ELECTRONIC TECHNOLOGIES, LLC AND SHOULD NOT BE USED WITHOUT WRITTEN PERMISSION		
	DIMENSION UNITS	SCALE	CURRENT REV DESC:
▽ = 0	mm		EC NO: 645050 DRWN: BSKANTHARAJU 2020/09/03 CHK'D: JCUATACERVAN 2020/09/18 APPR: JCUATACERVAN 2020/09/18
▽ = 0	GENERAL TOLERANCES (UNLESS SPECIFIED)		
▽ = 0	ANGULAR TOL ± 3.0°		INITIAL REVISION: DRWN: LPULLIAM 2005/06/21 APPR: BMOSEY 2005/06/22
▽ = 0	4 PLACES ±		
▽ = 0	3 PLACES ±		DOCUMENT NUMBER: SD-33012-002 DOC TYPE: PSD DOC PART: 001 REVISION: D
▽ = 0	2 PLACES ± 0.10		
▽ = 0	1 PLACE ± 0.3		MATERIAL NUMBER: SEE TABLE CUSTOMER: GENERAL MARKET SHEET NUMBER: 2 OF 5
▽ = 0	0 PLACES ±		
▽ = 0	DRAFT WHERE APPLICABLE MUST REMAIN WITHIN DIMENSIONS	THIRD ANGLE PROJECTION	DRAWING: C-SIZE SERIES: 33012

molex

MX150 RECEPTACLE TERMINAL

PRODUCT CUSTOMER DRAWING

THIS CHECKING - AID IS FOR SMALL POLARIZATION RIB TERMINALS ONLY

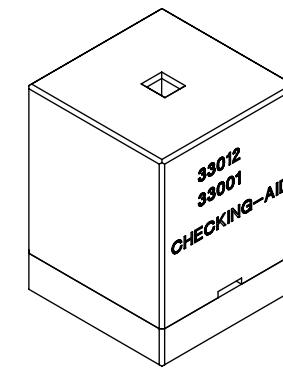

CHECKING - AID ASSEMBLY
SCALE 1:1

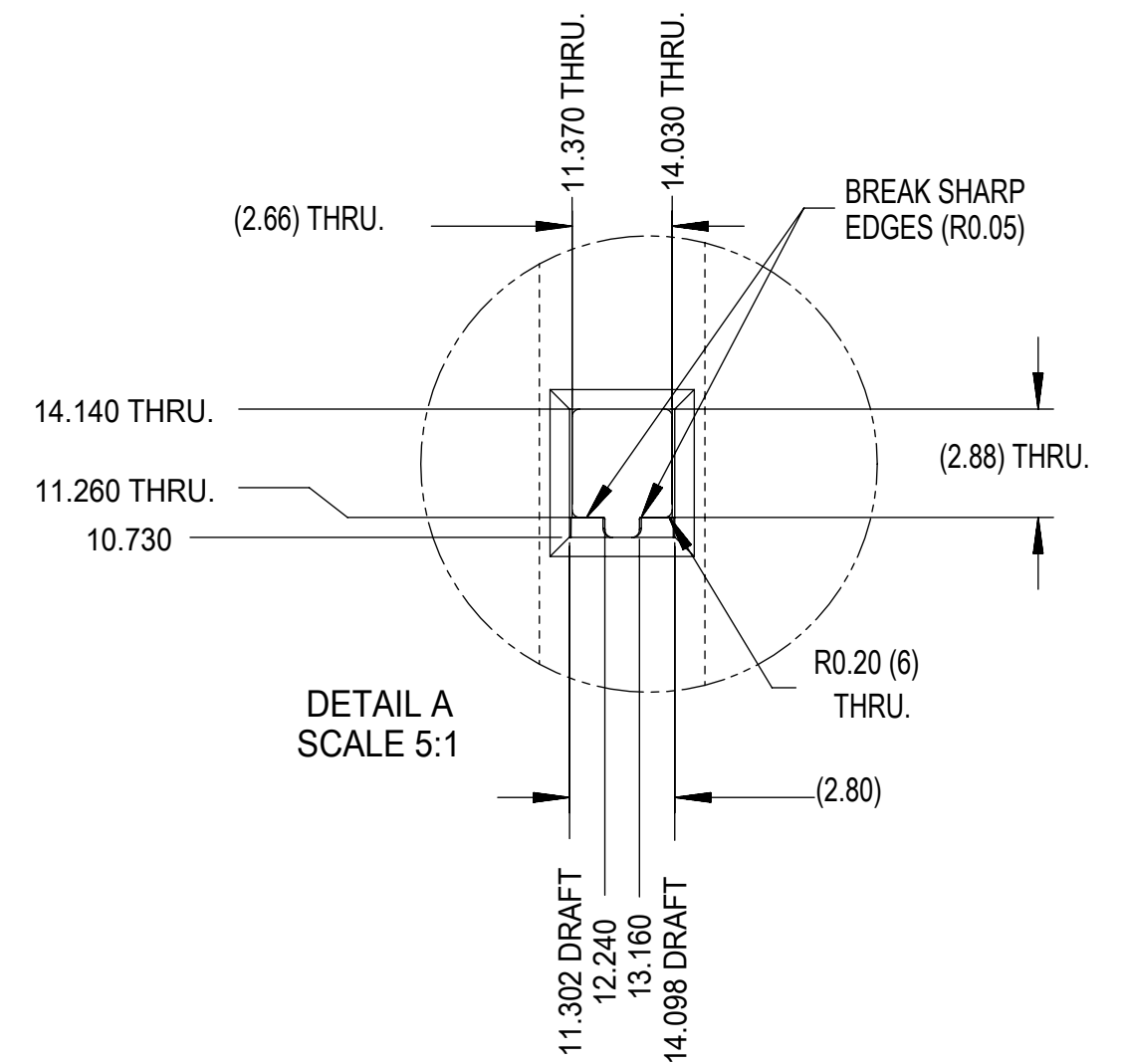
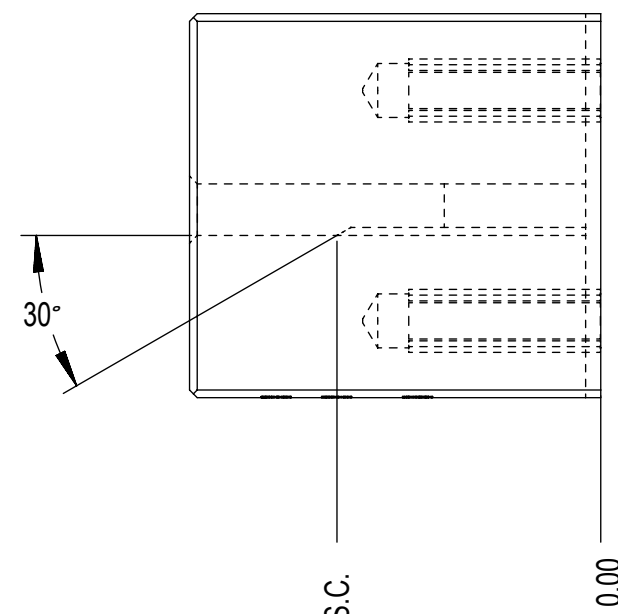
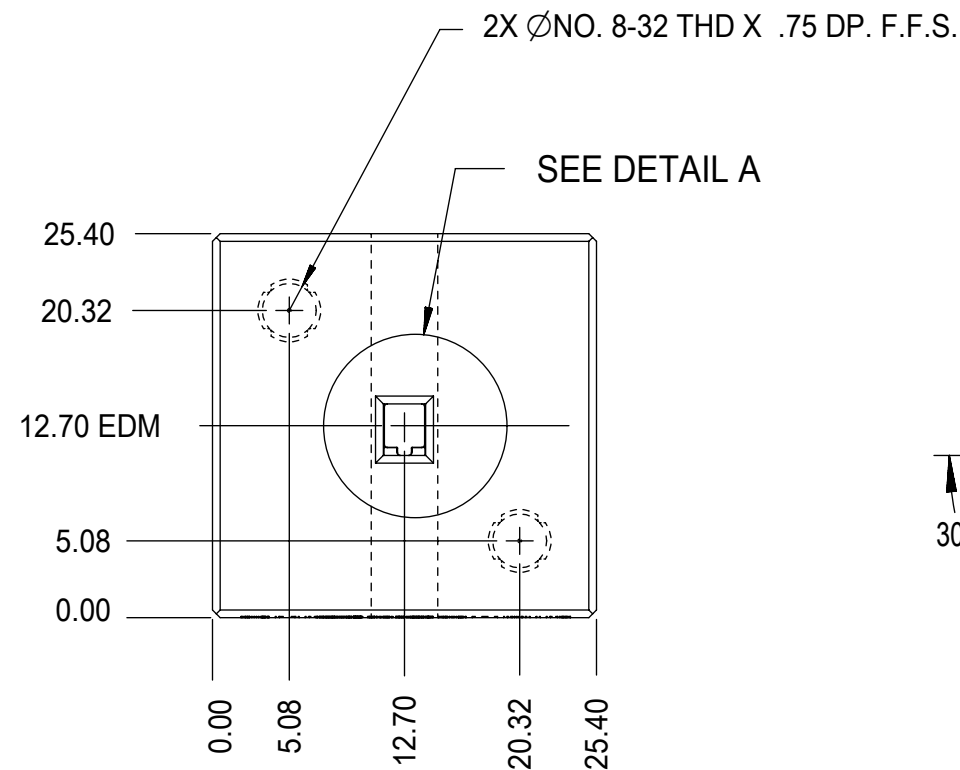

DETAIL A
SCALE 5:1

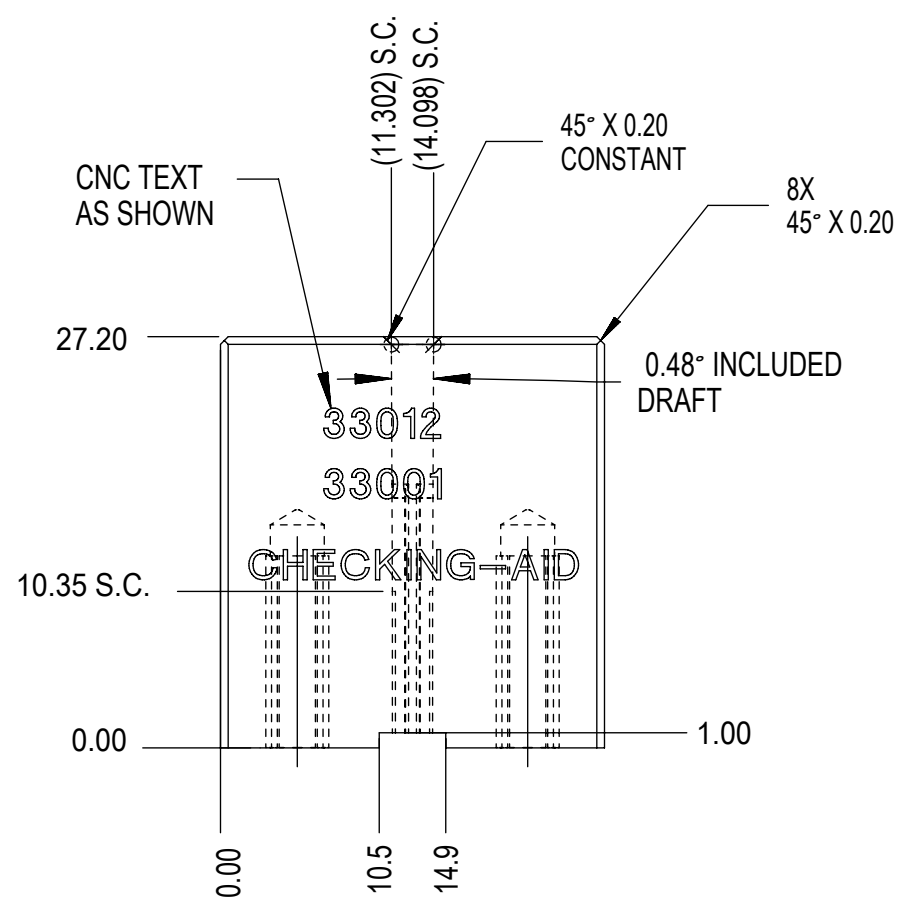

CHECKING - AID
UPPER

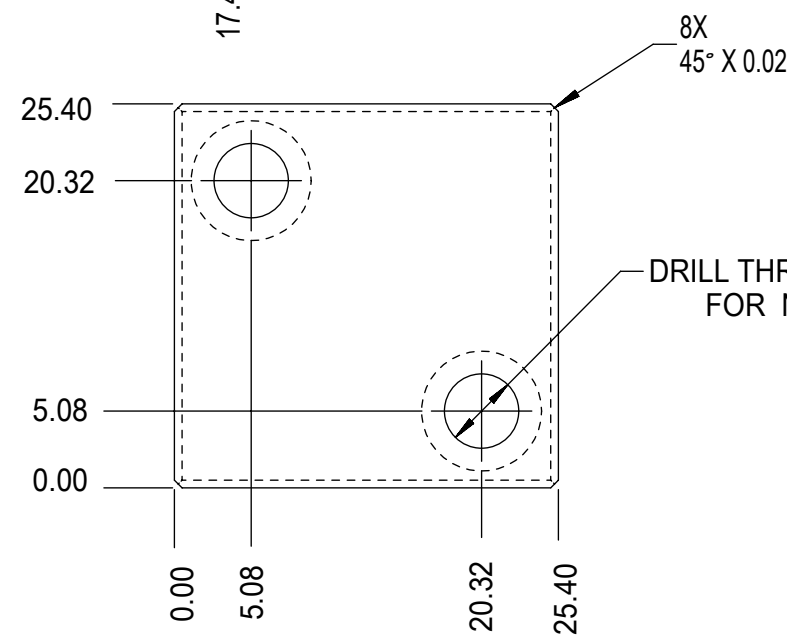

CHECKING - AID
LOWER

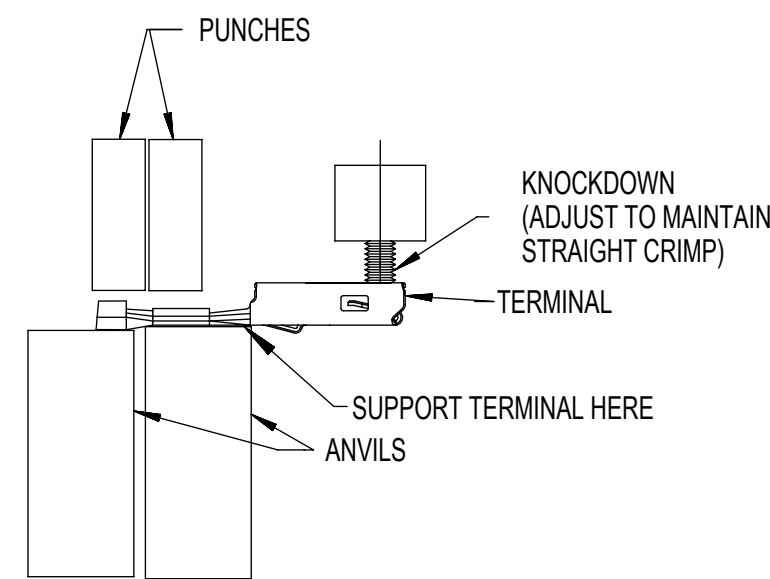

CRIMP REQUIREMENTS:

1. CRIMP STRAIGHTNESS MUST BE MAINTAINED USE A KNOCKDOWN TOOL LOCATED AS SHOWN TERMINAL BOX MUST NOT BE DEFORMED
2. AFTER CRIMPING, THE CRIMPED TERMINAL (AND UP TO 5 mm OF WIRE PAST THE INSULATOR CUTOFF TAB) MUST FIT FREELY INTO THE CHECKING-AID SHOWN ON THIS PAGE
3. FOR OTHER MECHANICAL REQUIREMENTS ON CRIMPED TERMINALS, REFER TO SAE/USCAR-21 (5-13-02) SECTIONS 4.2 (VISUAL INSPECTION), 4.2 (CROSS SECTION ANALYSIS) AND 4.4 (CONDUCTOR CRIMP PULLOUT FORCE)

UPPER & LOWER
CHECKING-AID
A2 TOOL STEEL
HARDEN & GRIND
ROCKWELL "C" 56-58

SYMBOLS				THIS DRAWING CONTAINS INFORMATION THAT IS PROPRIETARY TO MOLEX ELECTRONIC TECHNOLOGIES, LLC AND SHOULD NOT BE USED WITHOUT WRITTEN PERMISSION			
DIMENSION UNITS	SCALE	CURRENT REV		DESC:		MOLEX	
▽ = 0	mm	2:1				MX150	
▽ = 0	GENERAL TOLERANCES (UNLESS SPECIFIED)					RECEPTACLE TERMINAL	
▽ = 0	ANGULAR TOL ± 3.0°					PRODUCT CUSTOMER DRAWING	
▽ = 0	4 PLACES ±		EC NO: 645050	DRWN: BSKANTHARAJU	2020/09/03	DOCUMENT NUMBER	
▽ = 0	3 PLACES ±		CHK'D: JCUATACERVAN	2020/09/18		DOC TYPE DOC PART REVISION	
▽ = 0	2 PLACES ± 0.10		APPR: JCUATACERVAN	2020/09/18		SD-33012-002 PSD 001 D	
▽ = 0	1 PLACE ± 0.3		INITIAL REVISION:			MATERIAL NUMBER	
▽ = 0	0 PLACES ±		DRWN: LPULLIAM	2005/06/21	CUSTOMER		
▽ = 0	DRAFT WHERE APPLICABLE MUST REMAIN WITHIN DIMENSIONS		APPR: BMOSE	2005/06/22	GENERAL MARKET		
	THIRD ANGLE PROJECTION		DRAWING	SERIES	SHEET NUMBER		
	C-SIZE		33012	SEE TABLE GENERAL MARKET 3 OF 5			

DOCUMENT STATUS	P1	RELEASE DATE	2020/09/18	18:32:02
12	11	10	9	8

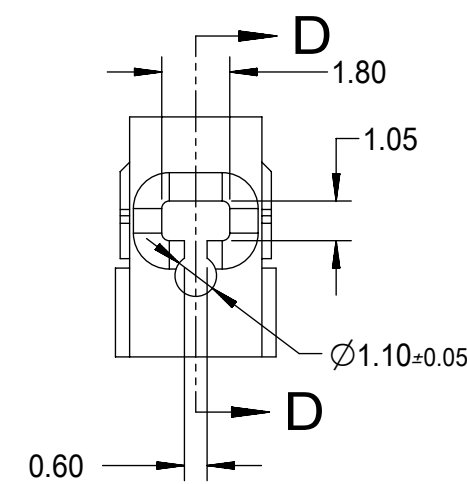
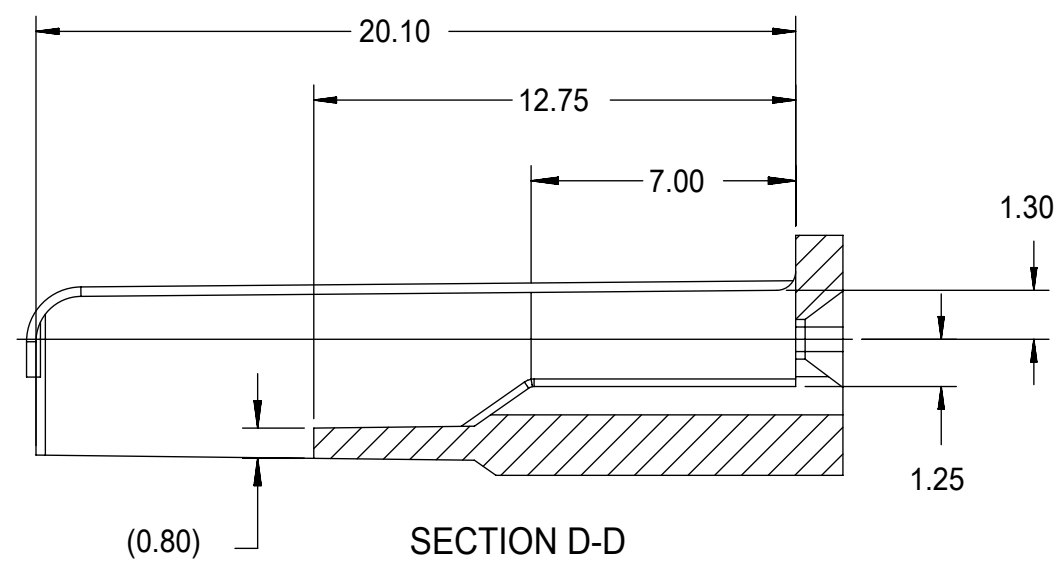
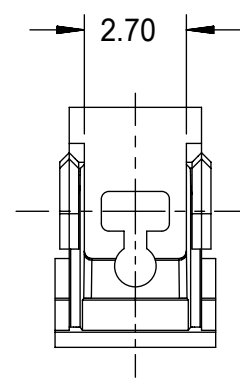

NOTES: UNLESS OTHERWISE SPECIFIED

1. TOLERANCES: LINEAR ± 0.10
ANGULAR $\pm 3^\circ$
2. ALL DRAFT WITHIN TOLERANCE.
3. MAX RADII ON ALL CORNERS SHOWN SHARP: 0.10
4. MAX FLASH PERMISSIBLE: 0.1
5. EJECTOR PIN MARKS PERMISSIBLE IF FLUSH TO 0.25 BELOW SURFACE.
6. MATERIAL: HOUSING/FINGER SPECIFICATION ENGINEERED FOR MATERIAL WITH THE FOLLOWING PROPERTIES:
A. FLEXURAL MODULUS = 4,500 TO 9,400 MPa
PER ASTM TEST D790
B. ELONGATION AT YIELD = 2.3% OR BETTER
PER ASTM TEST D638 TYPE V
7. CAVITY SPEC FOR USE ONLY WITH MOLEX RECEPTACLE
TERMINAL PART NUMBERS SPECIFIED ELSEWHERE ON THIS
DRAWING

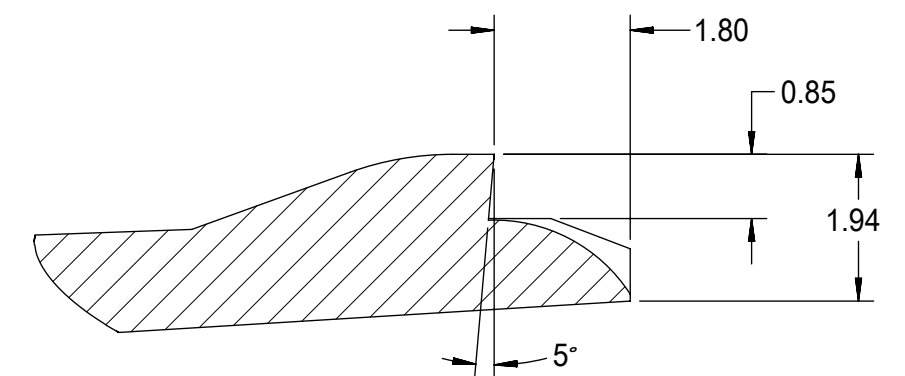
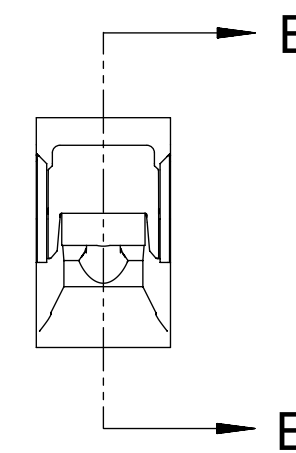
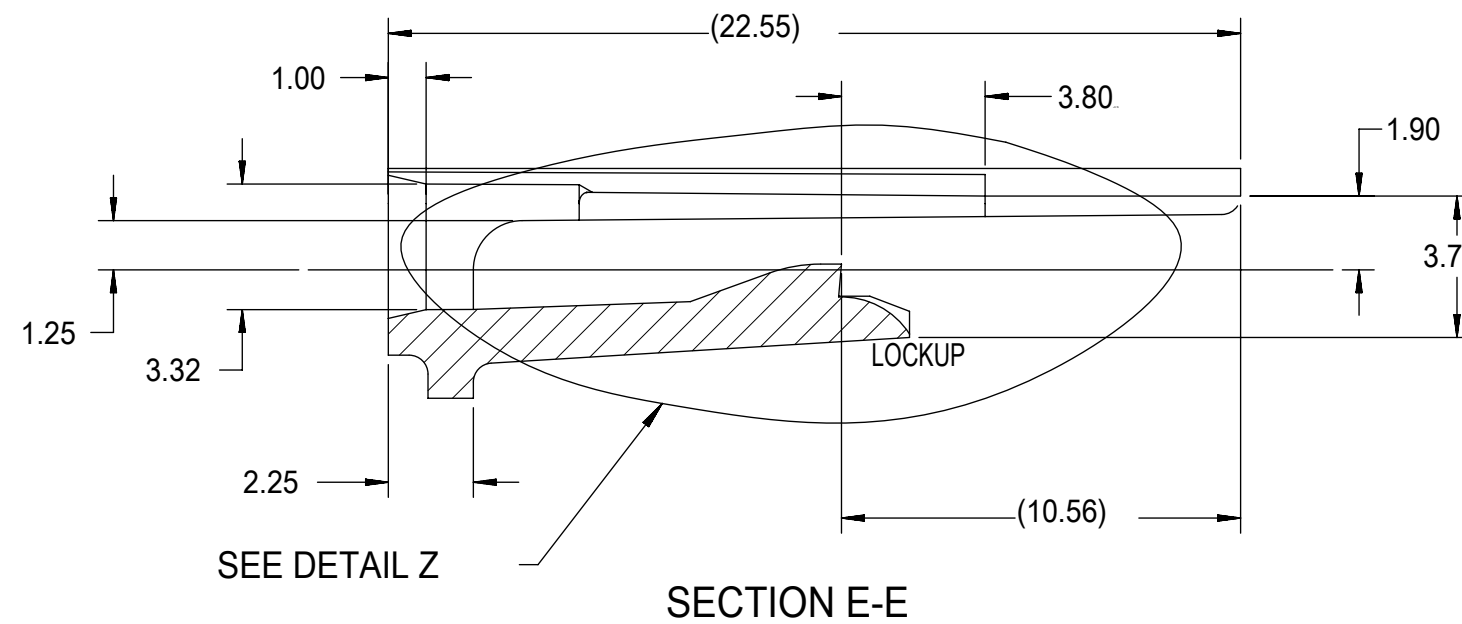
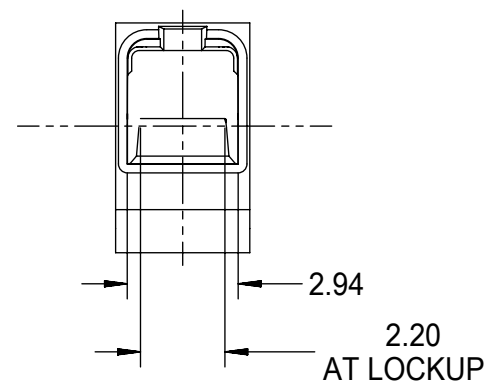

DETAIL Z
SCALE 20:1

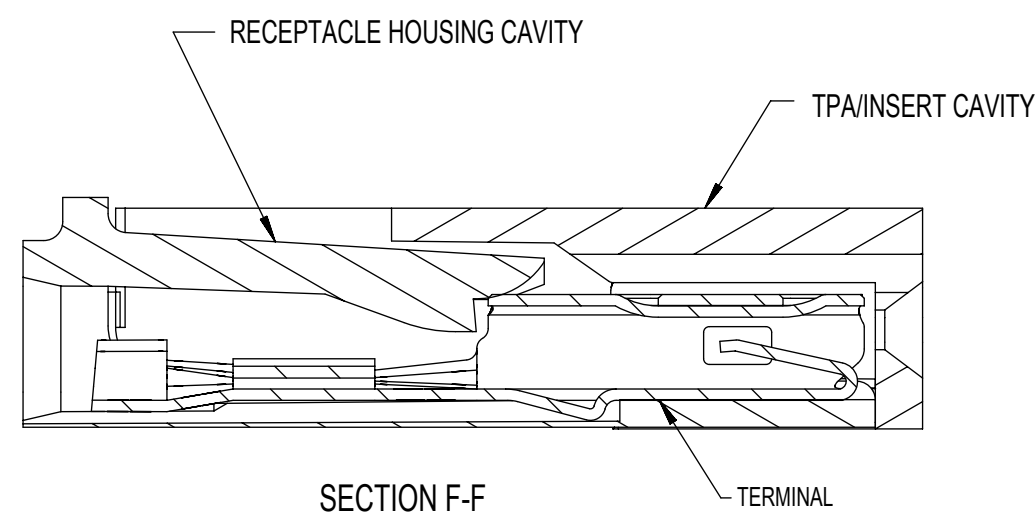

RECEPTACLE CAVITY ASSEMBLED VIEWS
FOR SMALL POLARIZATION RIB APPLICATIONS
FIG. 1

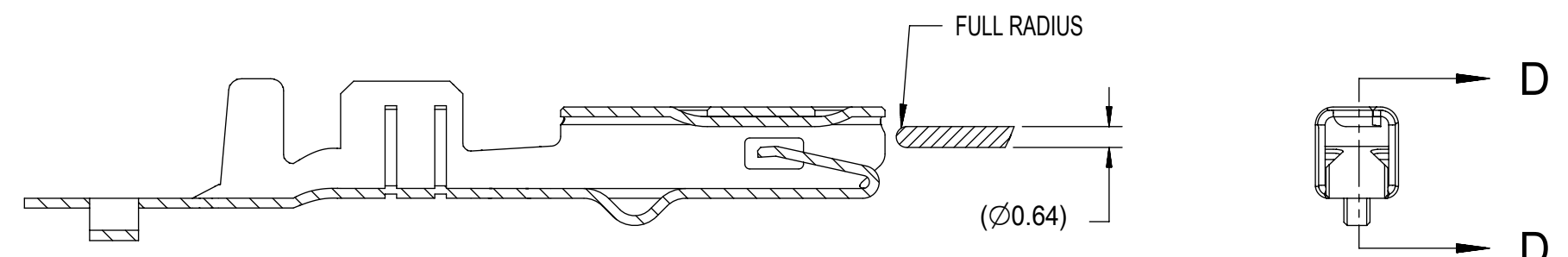
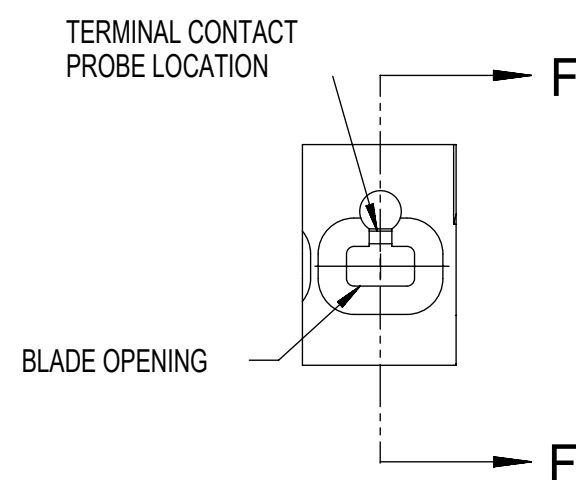

SECTION D-D
FOR LARGE POLARIZATION RIB APPLICATIONS
FIG. 2

PROBING DOWN THE
THROAT MUST USE
THIS TERMINAL PROBE

FOR PROBING INFORMATION REFERENCE
MOLEX MX150 APPLICATION SPEC AS-33472-100

PREFERRED PROBING LOCATION
IS NOT ON SPRING MEMBER

IF ELECTRICAL CONTINUITY PROBE
TOUCHES SPRING MEMBER USE
PROBING AS SHOWN IN FIG. 2

SYMBOLS		THIS DRAWING CONTAINS INFORMATION THAT IS PROPRIETARY TO MOLEX ELECTRONIC TECHNOLOGIES, LLC AND SHOULD NOT BE USED WITHOUT WRITTEN PERMISSION	
DIMENSION UNITS	SCALE	CURRENT REV DESC:	
$\nabla = 0$	mm	5:1	
$\nabla = 0$	GENERAL TOLERANCES (UNLESS SPECIFIED)		
$\nabla = 0$	ANGULAR TOL $\pm 3.0^\circ$		
$\nabla = 0$	4 PLACES	\pm	
$\nabla = 0$	3 PLACES	\pm	
$\nabla = 0$	2 PLACES	± 0.10	
$\nabla = 0$	1 PLACE	± 0.3	
$\nabla = 0$	0 PLACES	\pm	
$\nabla = 0$	DRAFT WHERE APPLICABLE MUST REMAIN WITHIN DIMENSIONS		
$\nabla = 0$	THIRD ANGLE PROJECTION	DRAWING	SERIES
		C-SIZE	33012
		EC NO: 645050	
		DRWN: BSKANTHARAJU 2020/09/03	
		CHK'D: JCUATACERVAN 2020/09/18	
		APPR: JCUATACERVAN 2020/09/18	
		INITIAL REVISION:	
		DRWN: LPULLIAM 2005/06/21	
		APPR: BMOSER 2005/06/22	
		DOCUMENT NUMBER	DOC TYPE DOC PART REVISION
		SD-33012-002	PSD 001 D
		MATERIAL NUMBER	CUSTOMER
		SEE TABLE	GENERAL MARKET
		SHEET NUMBER	
		4 OF 5	

molex

MX150
RECEPTACLE TERMINAL

PRODUCT CUSTOMER DRAWING

DOCUMENT NUMBER | DOC TYPE | DOC PART | REVISION

SD-33012-002 | PSD | 001 | D

MATERIAL NUMBER | CUSTOMER

SEE TABLE | GENERAL MARKET | SHEET NUMBER

4 OF 5

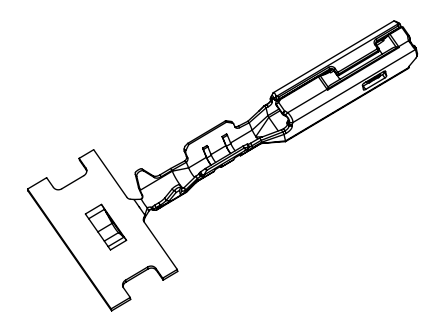

ISO VIEW
SCALE 2:1

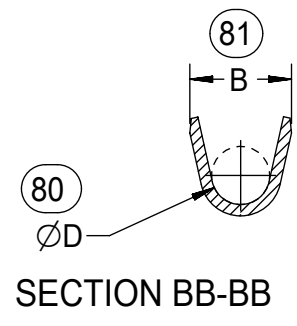
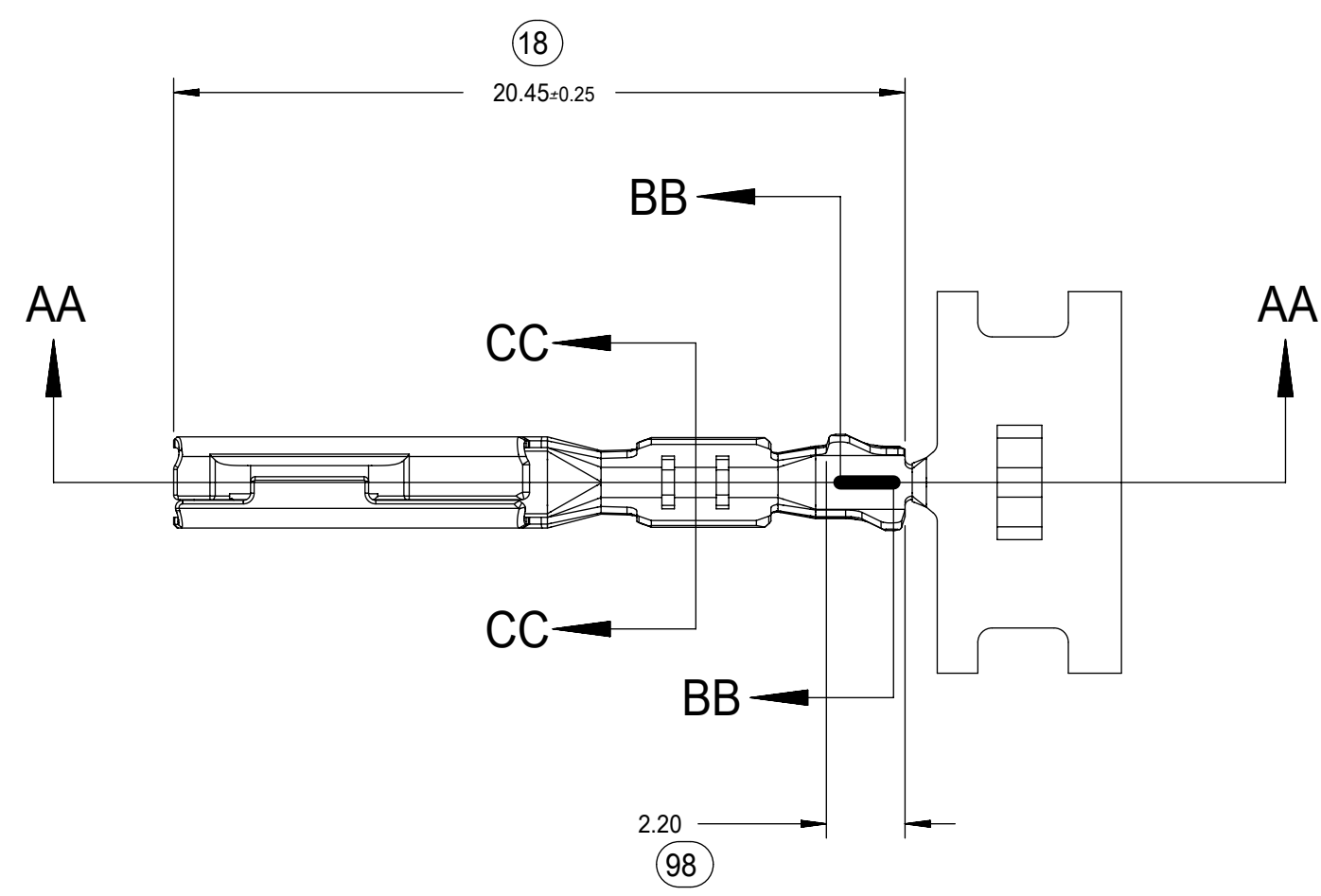

SECTION BB-BB

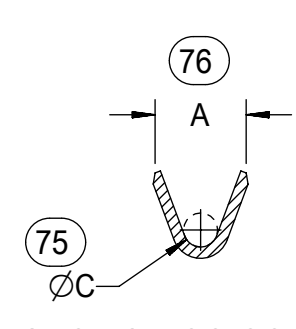

SECTION CC-CC

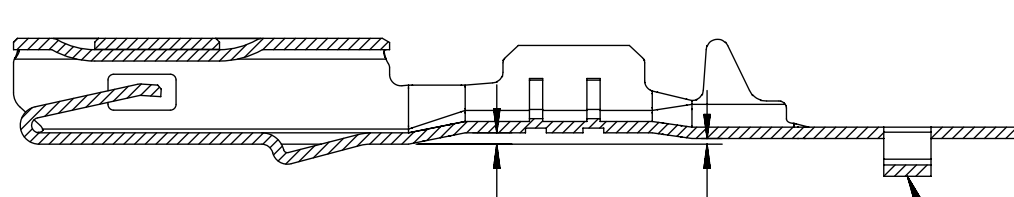
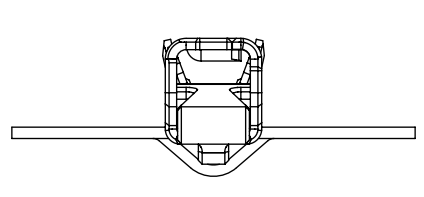

SECTION AA-AA
M3 GRIP CODE TERMINAL
SEE TABLE (SHEET 2) FOR PART NUMBERS

CARRIER BUMP DIRECTION
POINTS DOWN FOR TIN PLATED TERMINAL
POINTS UP FOR PRECIOUS METAL PLATED TERMINAL

SYMBOLS ▽ = 0 ▽ = 0 ▽ = 0 ▽ = 0 ▽ = 0 ▽ = 0 ▽ = 0 ▽ = 0 ▽ = 0 ▽ = 0	THIS DRAWING CONTAINS INFORMATION THAT IS PROPRIETARY TO MOLEX ELECTRONIC TECHNOLOGIES, LLC AND SHOULD NOT BE USED WITHOUT WRITTEN PERMISSION		DIMENSION UNITS: mm SCALE: 5:1		CURRENT REV DESC:				
	GENERAL TOLERANCES (UNLESS SPECIFIED) ANGULAR TOL ± 3.0°		EC NO: 645050 DRWN: BSKANTHARAJU 2020/09/03 CHK'D: JCUATACERVAN 2020/09/18 APPR: JCUATACERVAN 2020/09/18		MX150 RECEPTACLE TERMINAL				
	DRAFT WHERE APPLICABLE MUST REMAIN WITHIN DIMENSIONS		THIRD ANGLE PROJECTION		DRAWING: C-SIZE SERIES: 33012		PRODUCT CUSTOMER DRAWING		
	INITIAL REVISION: DRWN: LPULLIAM 2005/06/21 APPR: BMOSER 2005/06/22		DOCUMENT NUMBER: SD-33012-002 DOC TYPE: PSD DOC PART: 001 REVISION: D		MATERIAL NUMBER: SEE TABLE CUSTOMER: GENERAL MARKET		SHEET NUMBER: 5 OF 5		